



SERIP
INSPIRED BY NATURE

Nature

realised as concept

Serip, designs and produces nature-inspired sculptures resulting in decor elements and organic lighting that stands out for its thorough attention to detail. Expert in illumination since 1961, Serip's design consists in nature-inspired organic shapes where the disproportionate and uneven forms set Serip's design apart as exclusive and unique, based in nature's powerful distinguished elements, bringing to life the "Organic" concept.

Founded in 1961, Serip's heritage holds three generations of Portuguese craftsmanship highlighting a creative bridge between artisans and designers, providing a unique point of view of hand-made creation, contrasting with the production existing today.





art
of craftsmanship

The use of ancestral techniques takes us back to the past, on a journey into prehistory where our ancestors began to develop their skills. Generations have perfected the technique to this day, but without neglecting the essence of this manual process of unique characteristics that personifies the artistic production. Resulting in odd beauty pieces spiked with history.

Our technicians, artisans, sculptors and designers use knowledge in these techniques as a tool for the creation of contemporary art against industrialization, collecting the ancestral wisdom to give life to an organic style that characterizes only this brand.



a dramatic
game
of shadows
and light

VOA

Inspired by the marvellous ballet of the "Hirundo Rustica", a species of swallows that paint the skies like ballerinas. Their funnel-shaped bodies are also a Portuguese icon, which translates our soul in movements and shapes.

The unfindable configurations that they perform allows this singular collection to create beautiful visual compositions. Either in suspension or standing on the walls they create a dramatic game of shadows and light. Also, they can stay aligned, side by side, in an extreme organic and sharp textured tree branch creating extraordinary contrasts with the smooth and fluid shapes of their bodies.



AP1511/2 FO 10

VOA BRANCH SCONCE

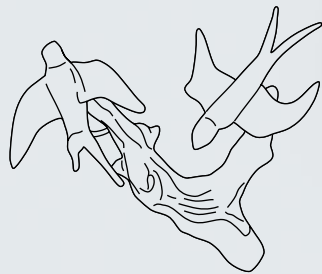

AP1511/2 35x32cm



AP1511/3 FO 10

VOA BRANCH WALL LAMP



AP1511/3 65x30cm

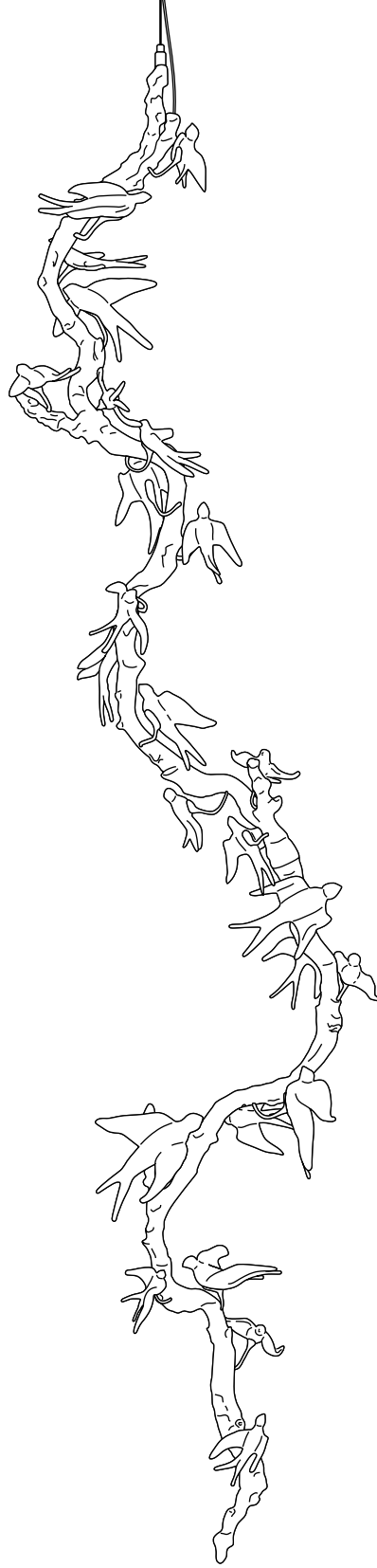

**VOA VERTICAL
BRANCH SUSPENSION**
CT3419/25 85x350cm



CT3418/10 FO 10

VOA HORIZONTAL BRANCH SUSPENSION

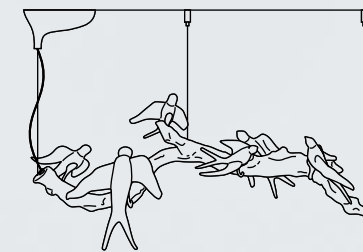

CT3418/6 100x45cm

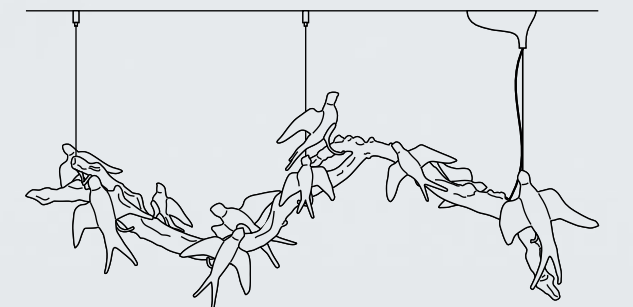

CT3418/10 145x55cm

FOLIO SINGLE LEAF SUSPENSION

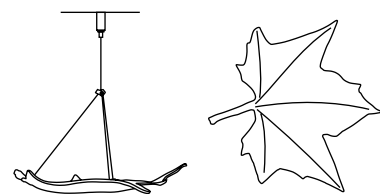

TD103 A 23cm
TD104 B 25cm

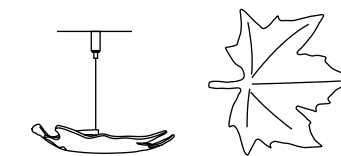

TD105 A 19cm
TD106 B 19cm
TD107 17cm

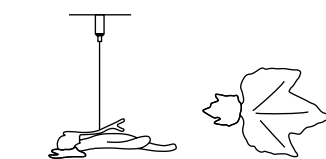

TD102 17cm

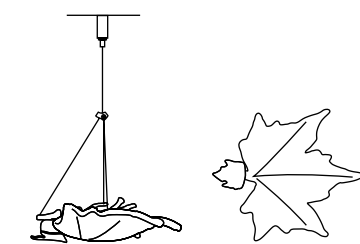

TD100 A 20cm
TD101 B 21cm

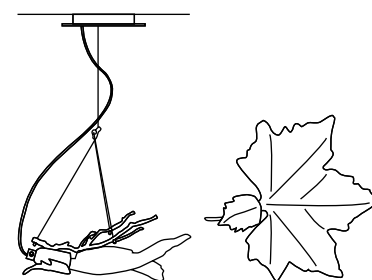

CT3403/1 23cm
CT3404/1 23cm



Folio

Inspired by the picturesque sight of Autumn and its fallen maple leaves.

Like a fragment of a whole, the natural form reflects the arbitrary composition of patterns in a complex set of reflections and contrasts resulting in a sense of an enchanted environment. Perfect for a mix and match of several decorative pieces and lighting fixtures.

The intensity of a still moment directly withdrawn from nature



CT3397/25 FO 10



CT3397/40 FO 10



CT3397/30 FO 10



FOLIO CIRCLE SUSPENSION



CT3397/25 Ø140x30cm

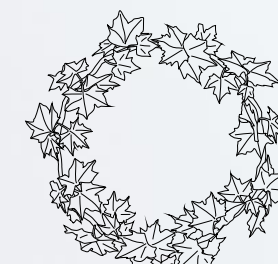

CT3397/40 Ø150x30cm



CT3397/30 Ø165x30cm



CT3401/3 FO 10

FOLIO SUSPENSION

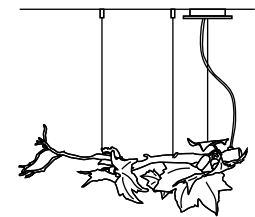

CT3401/3 70x27cm

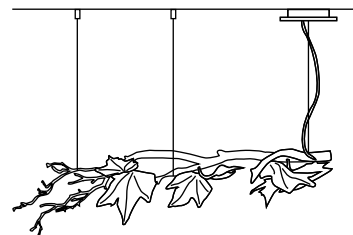

CT3396/6 100x30cm

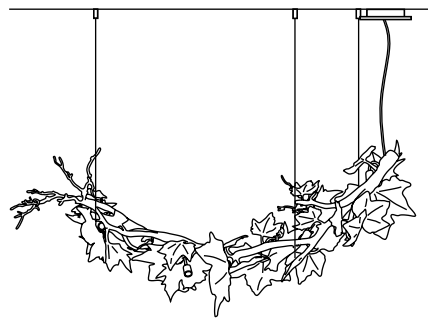

CT3409/12 125x53cm

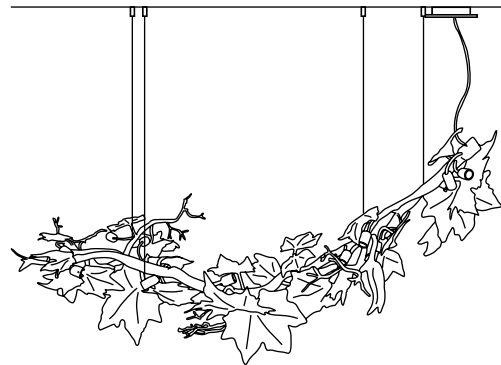

CT3409/14 150x53cm



CT3409/12 FO 10



AP1499/4/R FO 10

**FOLIO
WALL
LAMP**



AP1499/4/R 70x105cm



AP1499/4/L 70x105cm



AP1498/3 FO 10

**FOLIO
SCONCE**



AP1498/3 32x32cm



PD101 FO



PD100 FO



PD102 FO

**FOLIO
DECORATIVE
WALL**



PD102 12,5x17cm



PD100 16x17cm



PD101 24x24cm

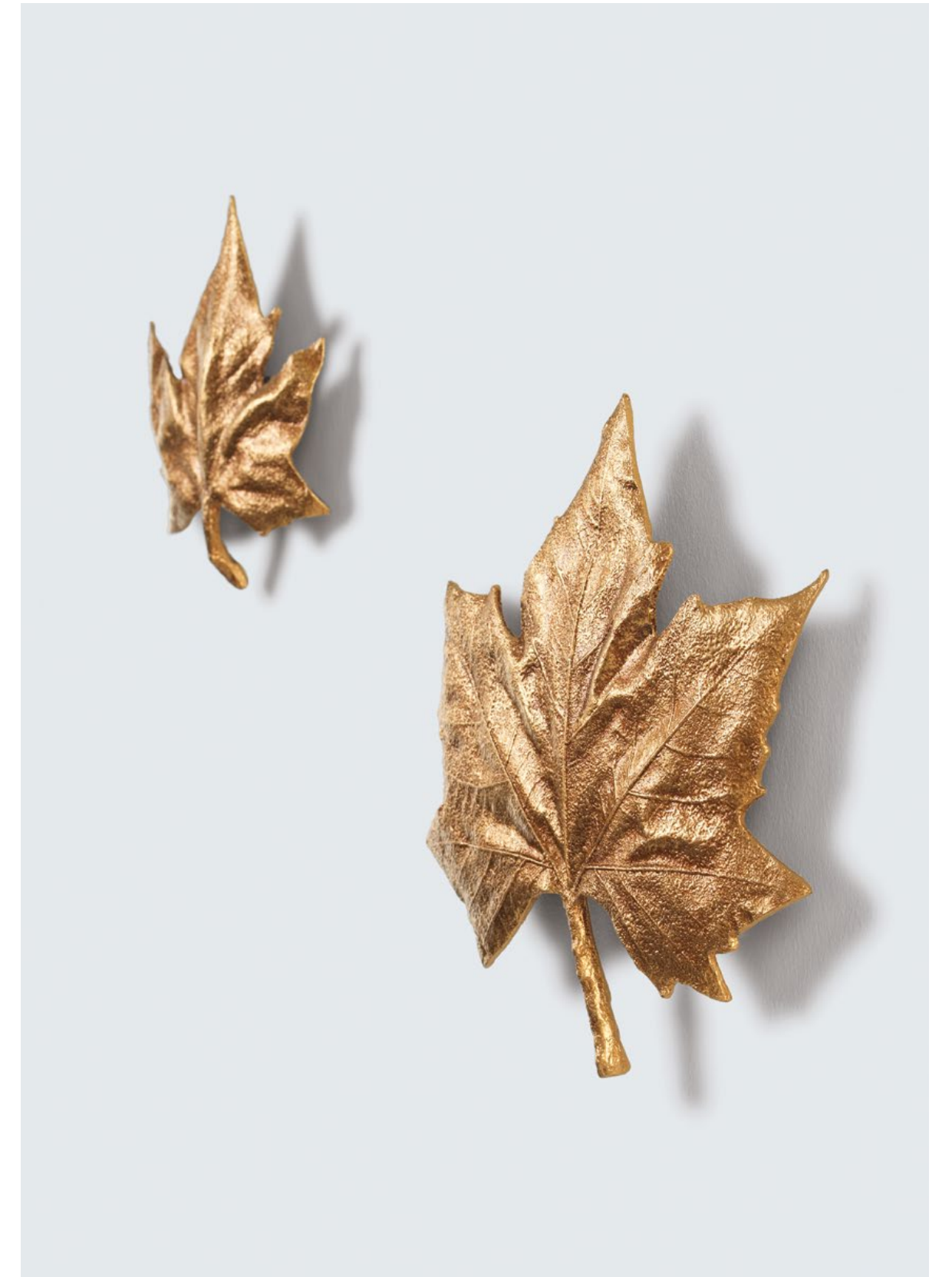

An art installation

Pathleaf

As a lighting wonder, the Pathleaf Collection exists in high contrast for a differential and artistic outcome. It is quite a dramatic collection, closely connected to its nature inspiration, presented almost as an art installation, being able to embrace different designs and extensions. The Pathleaf allows modular choices and indirect light, conveying a visual arrangement of great dynamism and an organic complement for wall and ceiling decorations, just like a real natural painting.



PL376/32 FO + CO + TA + RO

PATHLEAF
CIRCLE
WALL/CEILING LAMP

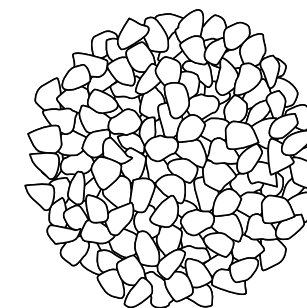

PL376/32 Ø140cm

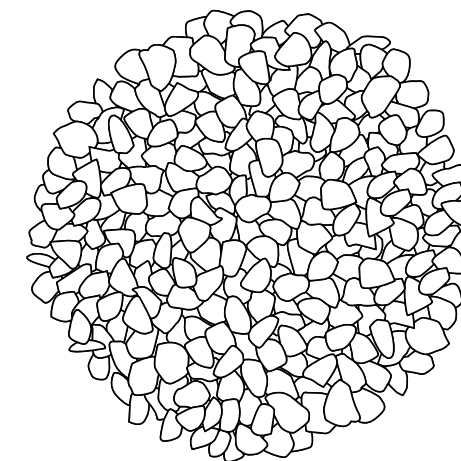

PL372/68 Ø210cm

**PATHLEAF
CLIMBER
WALL LAMP**

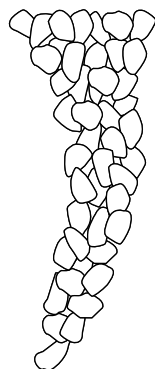

AP1501/12 62x153cm



AP1503/24 62x270cm

AP1501/12 PR + CH + FP + FO + CO + FO/PB



AP1503/24 CH + FP + FP/PB + FO/PB



AP1504/36 FO + FP + RO + CO + FO/PB + TA



AP1502/24 CH + FP + FO + RO + CO



**PATHLEAF
CLIMBER
WALL LAMP**

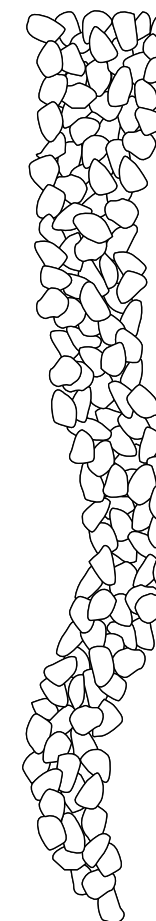

AP1504/36 59x343cm



AP1502/24 59x204cm



a colourful
atmosphere
of rainy drops

Bijout

As beautiful and delicate as nature itself, the Bijout carries a romantic and whimsical sense of detail. The gentle glass pieces are designed to contrast directly with the complex and condensed bronze structure, in a combination of light and movement, and a multitude of colours and weights. In order to define a certain refinement to an interior design concept, the Bijout collection guarantees elegant and graceful details for compelling results.



CT3263/18 CH 10 + 42

BIJOUT
OVAL SUSPENSION

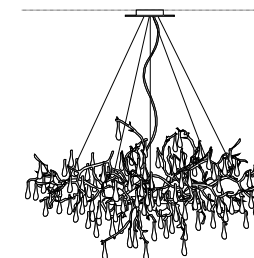

CT3268/8 110x65 cm

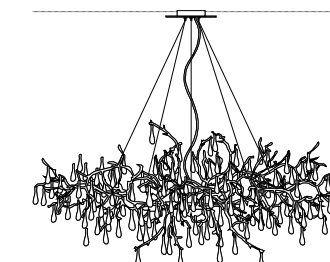

CT3263/12 135x65 cm

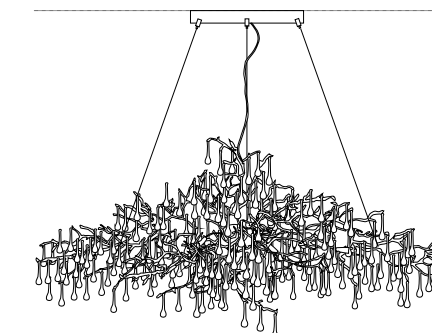

CT3263/18 180x80 cm

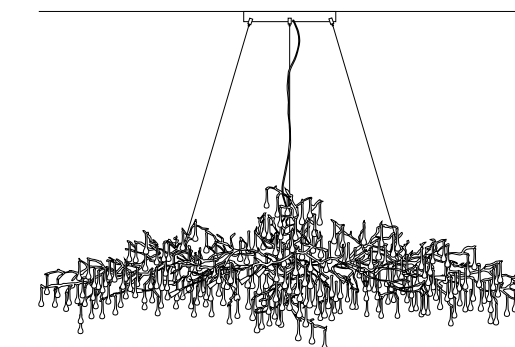

CT3263/26 265x80 cm



**BIJOUT
RING
SUSPENSION**

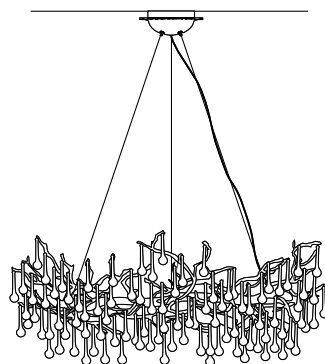

CT3413/12 Ø105x40cm

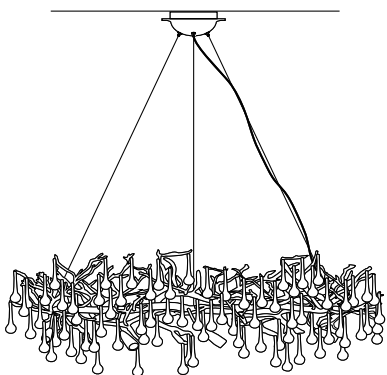

CT3413/16 Ø120x40cm

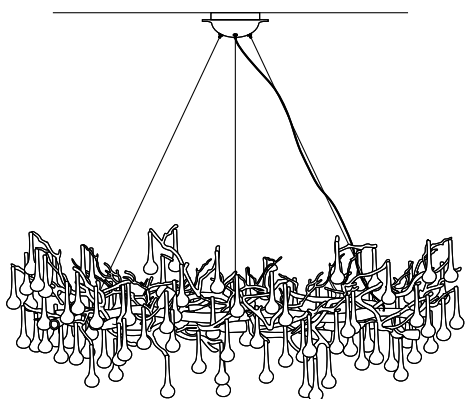

CT3413/22 Ø140x40cm

CT3413/22 FO/PB 10 + 43 + 44



An entangled
blooming lotus

Lotus

Lotus design follows the inherent evolutionary disposition of an organism, proposing a spiral arrangement almost like a living sculpture of motion and growing light sources. The egg-shaped glass pieces emit light to involve the entire piece as a single organic silhouette, a Serip trademark throughout all lighting designs, revealing an interesting glass work that includes bubbles in each piece - factor that confers unique characteristics to the light emission.





CT3408/25 FO/PB 10

LOTUS
HORIZONTAL SUSPENSION

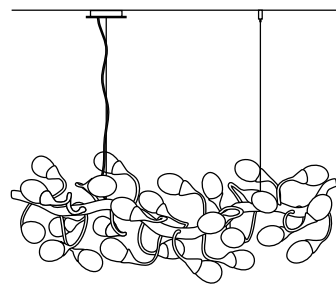

CT3408/25 130x45cm

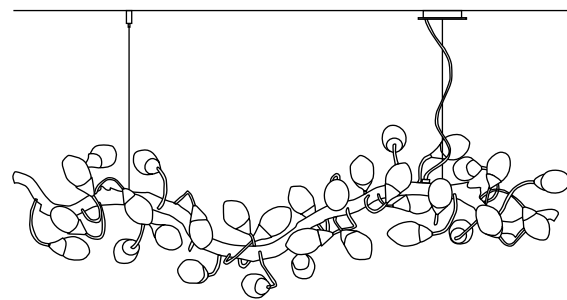

CT3376/33 175x55cm

LOTUS
ROUND SUSPENSION

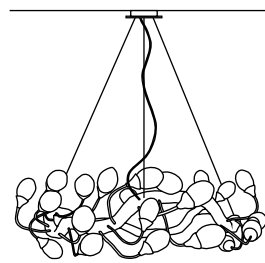

CT3402/36 Ø110x40cm



CT3402/36 FO/PB 10



Emphasizing
the purity of
water lilies

Nenufar

Ethereal and whimsical, the Nenufar Collection stands closely connected to its direct inspiration, the aqueous nature. Beyond its particular dense structure and closed shape in some designs, it seeks an uncanny levitating sense, allowing multiple perspectives through the carefully crafted Murano glass pieces. Through the glass specifications, the Nenufar achieves diffuse lighting providing an alluring romantic sense, reminiscent of the natural beauty of nature.

NENUFAR PLAFOND

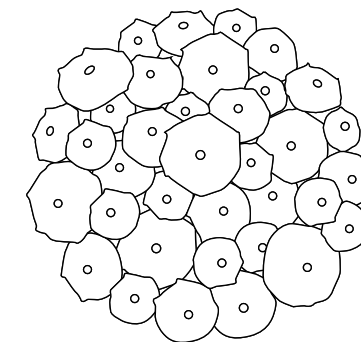

PL380/28 Ø145cm

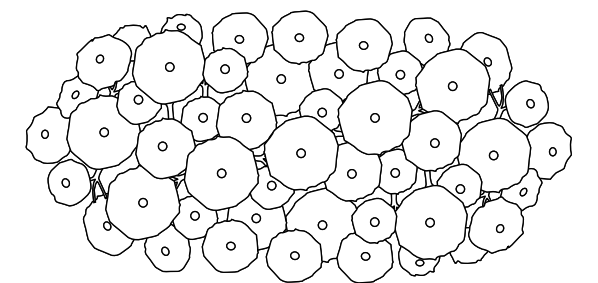

PL368/36 235x120cm



NENUFAR BONSAI SUSPENSION

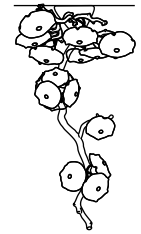

CT3384/15 Ø110x150cm

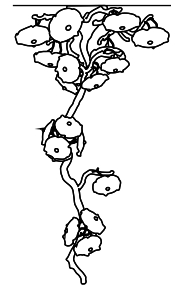

CT3384/18 Ø110x186cm

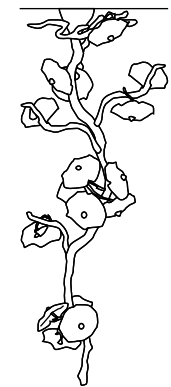

CT3384/27 Ø110x250cm

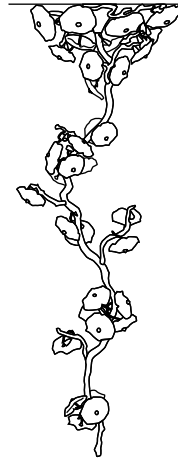

CT3384/35 Ø110x300cm

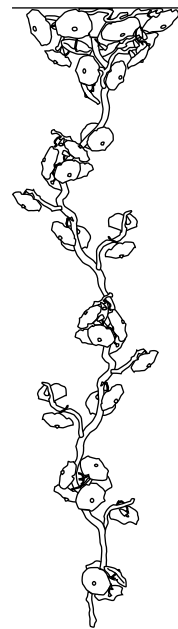

CT3384/44 Ø110x410cm



**NENUFAR
WALL LAMP**

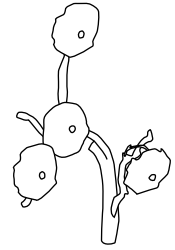

AP1475/4 60x82cm

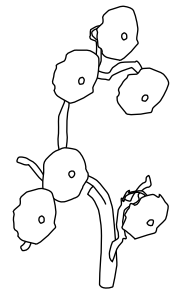

AP1475/6 72x110cm

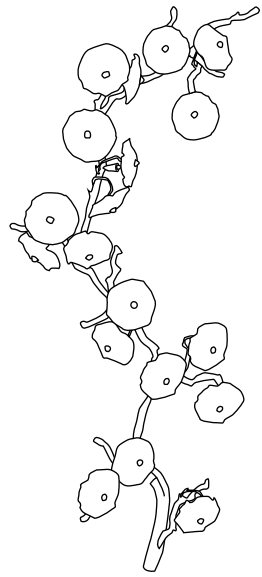

AP1475/21 110x250cm



AP1475/6 FP 10



AP1475/4 FO 10



a phenomenon
of nature

Geyser

The intrinsic force of a geyser carries a blend of aggressiveness and beauty in an unlikely harmony between strength and fragility, establishing the basis of the Geyser Collection. The glass primacy embodies the piece with vigour and energy aiming towards the most intense visual lighting experience.

GEYSER
PLAFOND

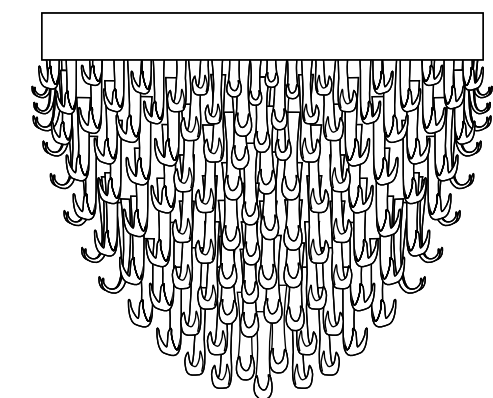

PL379/22 244x190cm

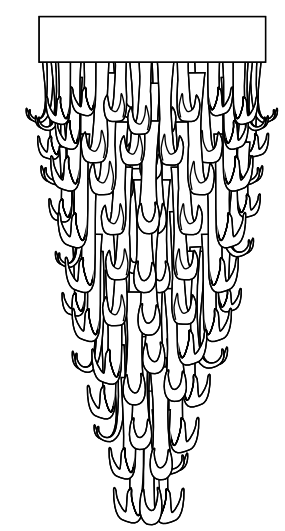

PL381/15 Ø100x200cm



AP1496/2 FP 15 + 28 + 29



AP1496/2 FO 04 + 06 + 23



AP1496/2 FP 32 + 39 + 42

**GEYSER
WALL LAMP**

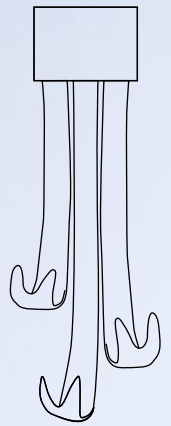

AP1496/1 30x75cm

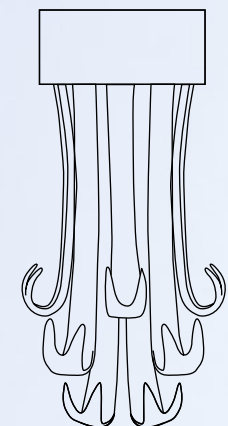

AP1496/2 40x75cm



Inspired
by winter
water drops

Aqua

The Aqua Collection is an iconic set of the Serip family, both by its element of inspiration and by its inherent association with our identity, expressing a strong connection to our main inspiration source, nature. The bronze structure expands in entangled branches that lead to floating glass pieces, a characteristic that concedes an airy touch together with its delicate and elegant look, concepts visible in the smallest detail of the glass drops.



AQUA
CONICAL SUSPENSION

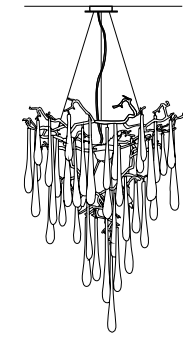

CT3259/8 Ø70x100cm

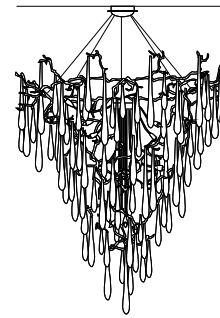

CT3272/19 Ø115x125cm

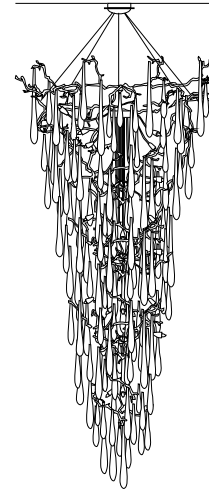

CT3350/22 Ø100x220cm

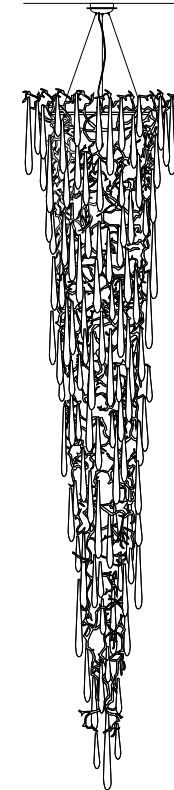

CT3375/32 Ø80x350cm

CT3272/19 PR 14



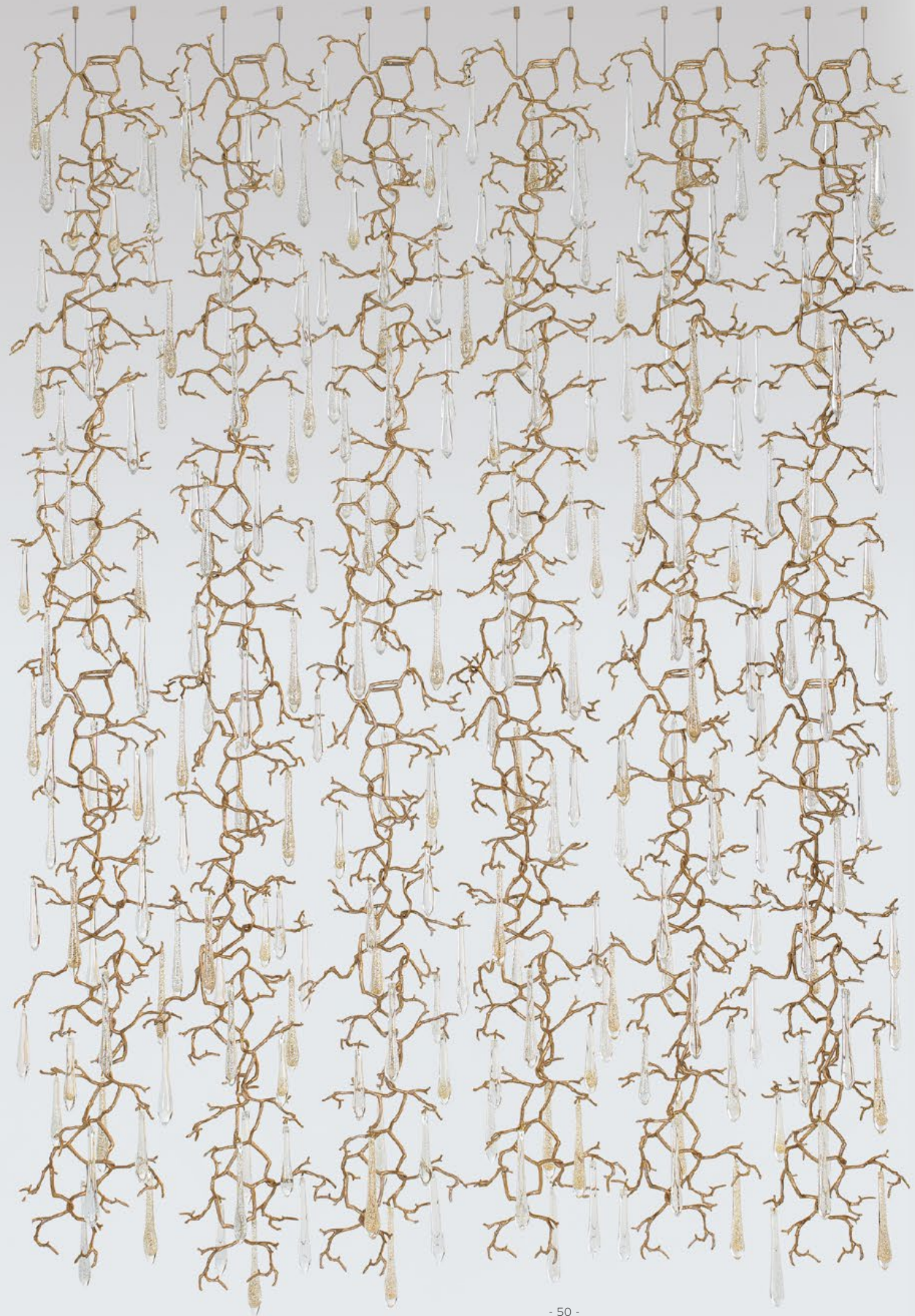

AQUA
DECORATIVE PANEL

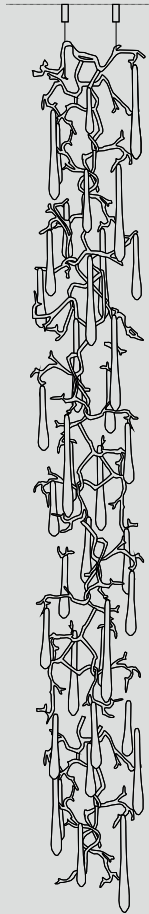

TD108 45x345cm





The raw side
of nature

Niagara

Visually embracing the tenacious and raw side of nature, this collection transpires a very close visual density of its inspirational waterfall through the glass pieces. The solid glass presence represents the untamed motion of water shaped, completed with organic patterns in a game of transparency and opacity, a characteristic that counteracts inertia and enhances movement. The metal structure follows the main concept with vines in a never ending fluid motion.

**NIAGARA
SUSPENSION**



CT3410/1 Ø70x58cm

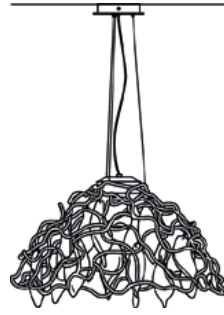

CT3411/1 Ø80x55cm

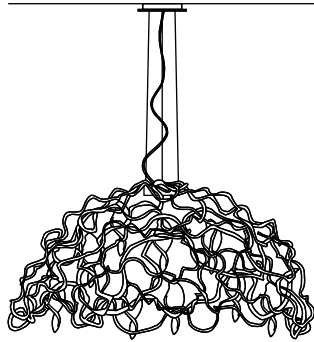

CT3387/1 Ø110x75cm



CT3410/1 FP 10



CT3411/1 FP 10



The liquid state
directly withdrawn
from nature

Liquid

Pure and dazzling, the Liquid collection presents itself intentionally as a dense design. The vast branched pattern surrounds a considerable sized glass piece just as an embrace of nature, where the movement of the structure tries to reach the fall of a drop of water. Due to the steel cable solution, the Liquid collection is ideal for situations that require some structure and magnificence, achieving a status of lighting sculpture.



**LIQUID
SINGLE
SUSPENSION**

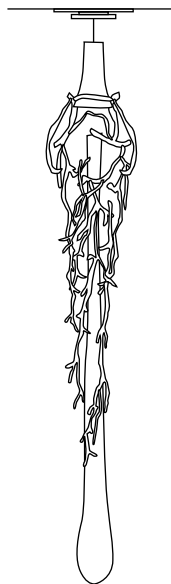

PL375/1 Ø15x90cm



CORAL
FLAT
SCONCE

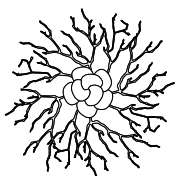

AP1488 Ø80cm

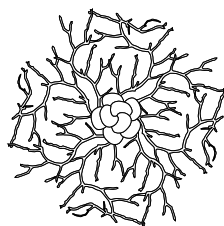

AP1487 Ø105cm

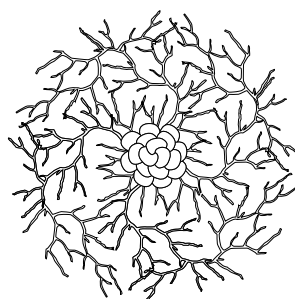

AP1486 Ø140cm

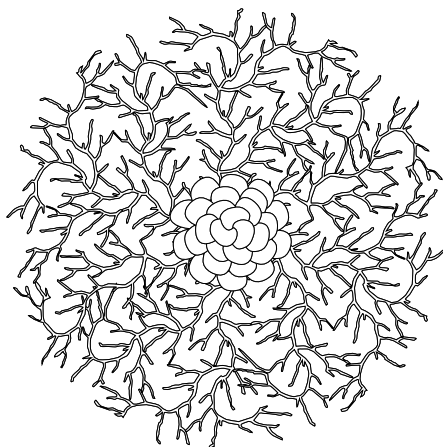

AP1485 Ø210cm

AP1485 RO

The skeletons
of underwater
structures

Coral

Inspired by the beauty and natural complexity of coral reef shapes, the Coral Collection stands as a dense structure of intertwined metal branches aiming for a faithful representation to its nature and visual impact. The glass pieces fall into the glimpse of marine organisms in a visual combination of great impression.





**CORAL
FLAT
SCONCE**
AP1486 Ø140cm

AP1486 FP



AP1500 FO

**CORAL
WALL LAMP**

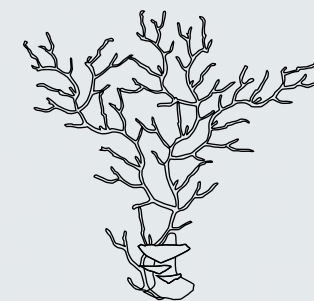

AP1500 120x110cm

**CORAL
FRAGMENTED
SUSPENSION**

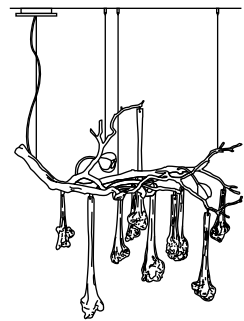

CT3393/4 78x70cm



Inspired by
the shapes
of fish scales
and sea life

Carpa

The unusual shape of the Carpa collection pieces stand as a closed design of intense asperity. By modular creation, this collection presents a strong decorative presence with subtle highlight through its diffuse and indirect lighting. Designed entirely with the same material, it gets its shape through the visual lines of scales of marine organisms, a dynamic combination to complement an interior design concept.



**CARPA
SCONCE**



AP1489/L 30x40cm



AP1489/R 30x40cm

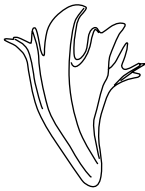

AP1490/L 25x30cm



AP1490/R 25x30cm



AP1491/L 19x27cm



AP1491/R 19x27cm



AP1491/L + AP1490/R + AP1489/L FO



AP1491/L + AP1490/L + AP1489/L + AP1490/L FO



Inspired by the
arched shape
of a water fountain

Icarus

With a particular design, the Icarus collection looks as if a frozen fountain was taken directly from its natural setting. Designed like a sculpture by its close resemblance to its nature, the light emerges within the crafted glass, following the liquid motion that grows supported by the bronze central branch.

Its intense decorative character commits to its dramatic visual presence, resulting in a piece of high contrast and differential highlight



CT3389/14 FP 10

**ICARUS
WALL LAMP**

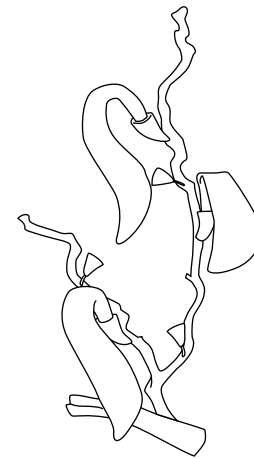

AP1497/6 70x130cm

**ICARUS
SUSPENSION**

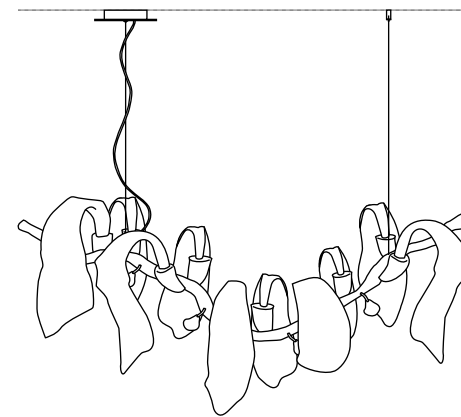

CT3389/14 135x65cm



AP1497/6 10

Inspired
by the
full moon
contrast light

Luna

By the full moon
contrasting light arises
the Luna Collection,
modern compositions
with multiple rings
of diffuse lighting.
Designed under a
mystical criteria of
patterns, the circular
pieces assume a position
of high contrast, detail
that incorporates them
as distinctive and
eccentric.



CT3392 CH 10

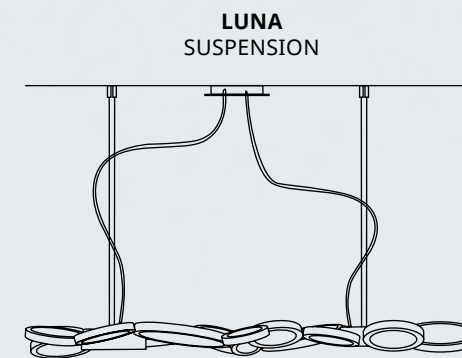

CT3392 160x70cm

CT3407 FO 10



LUNA
SUSPENSION

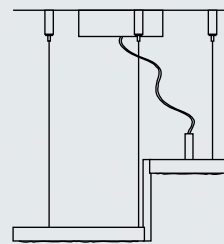

CT3407 41x20cm

CT3405 FO 10



LUNA
SUSPENSION

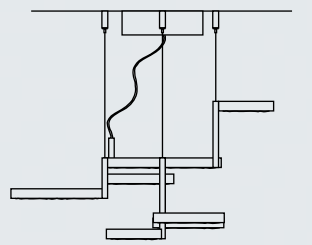

CT3405 72x37cm

CT3406 FO 10



LUNA
SUSPENSION

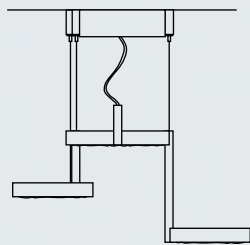

CT3406 44x26cm

a dedication
to Piet Mondrian

Mondrian

Inspired by the unique life of the desert sands, Mondrian Collection is a simple dedication to the determinant Dutch painter Piet Mondrian and his abstraction work based on strict grids and three primary colours. The evident pattern in each Serip Mondrian piece relates directly to the lines resulting from the wind touching the sand, a reflection present in a luminous shape resembling the artist's signature grid. By its modular concept, the collection design falls into the category of collections with artistic presence, where light compositions achieve an artistic installation sense.





AP1493/1 FP 10



AP1494/3 FP 10

**MONDRIAN
WALL LAMP**



AP1493/1 13x47cm

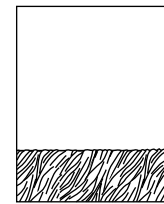

AP1494/3 31x40cm

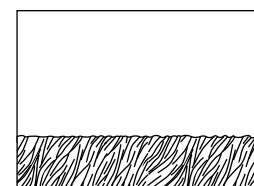

AP1495/5 48x35cm

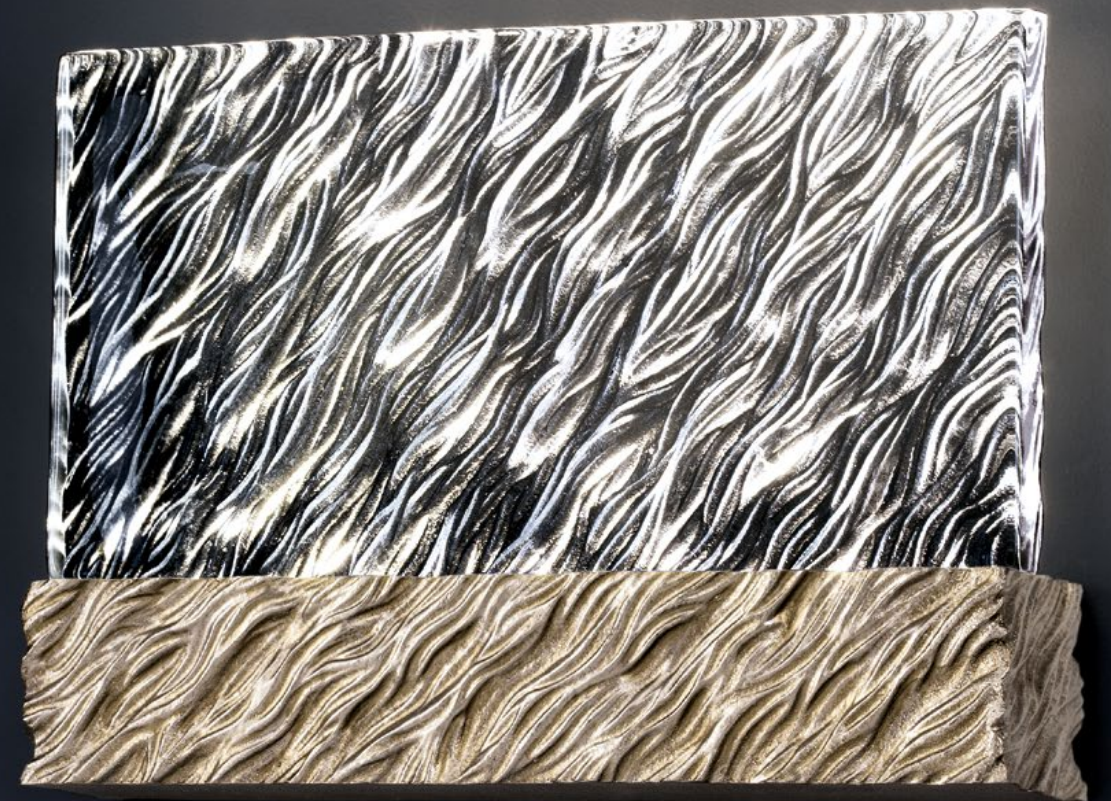

AP1495/5 FP 10

**MONDRIAN
SUSPENSION**

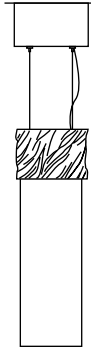

CT3398/1 15x45cm

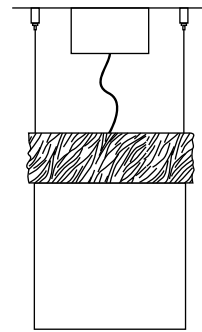

CT3399/3 33x39cm

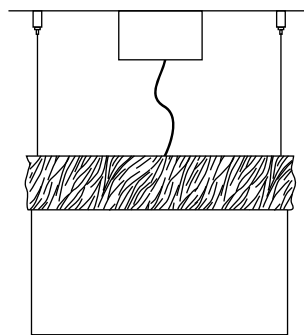

CT3400/5 51x33cm



CT3399/3 FO 10



CT3398/1 FP 10



CT3400/5 FP 10

Inspired by the surrealism of Dali sculptures and paintings

Dali

Dali Collection is inspired by Dali surrealist sculptures and paintings, visually emerged from an uncanny parallel world. These lighting pieces open an endless possibility for light compositions and impressive contrasts and highlights. Standing as a humble dedication to such a great and outstanding artist, the Serip Dali Collection pieces present themselves as an organic decorative installation of diffuse lighting for creative and bold interior designs.



AP1482 42x53cm



AP1483 37x51cm

DALI
WALL LAMP



AP1483 FP 10



AP1482 FP 10

All rights reserved, copyright © Serip® 2019

For all models, texts, layout and images.

Serip reserves the right to change its models without prior notice and/or the specifications thereof. Serip manufactures unique custom-made lighting and complements sculptures and once the manufacturing is manual the pieces may differ from each other. Each piece has its own identity and therefore is unique. Each piece is labelled with a reference and certified for the country of destination. The designs, texts, layouts or images are protected by copyright and/or industrial design rights. No part may be made public, reproduced or altered in any form for commercial purposes by third parties, including resellers, distributors, e-shops and others, without prior consent, or express written permission of the company Mário J. Pires, Lda. owner of Serip ® brand.

MADE IN PORTUGAL
Since 1961

www.serip.com.pt



SERIP®

www.serip.com.pt

